

# Embassy

2 RAIL TUBULAR IRON SERIES, STYLE LF-EM02

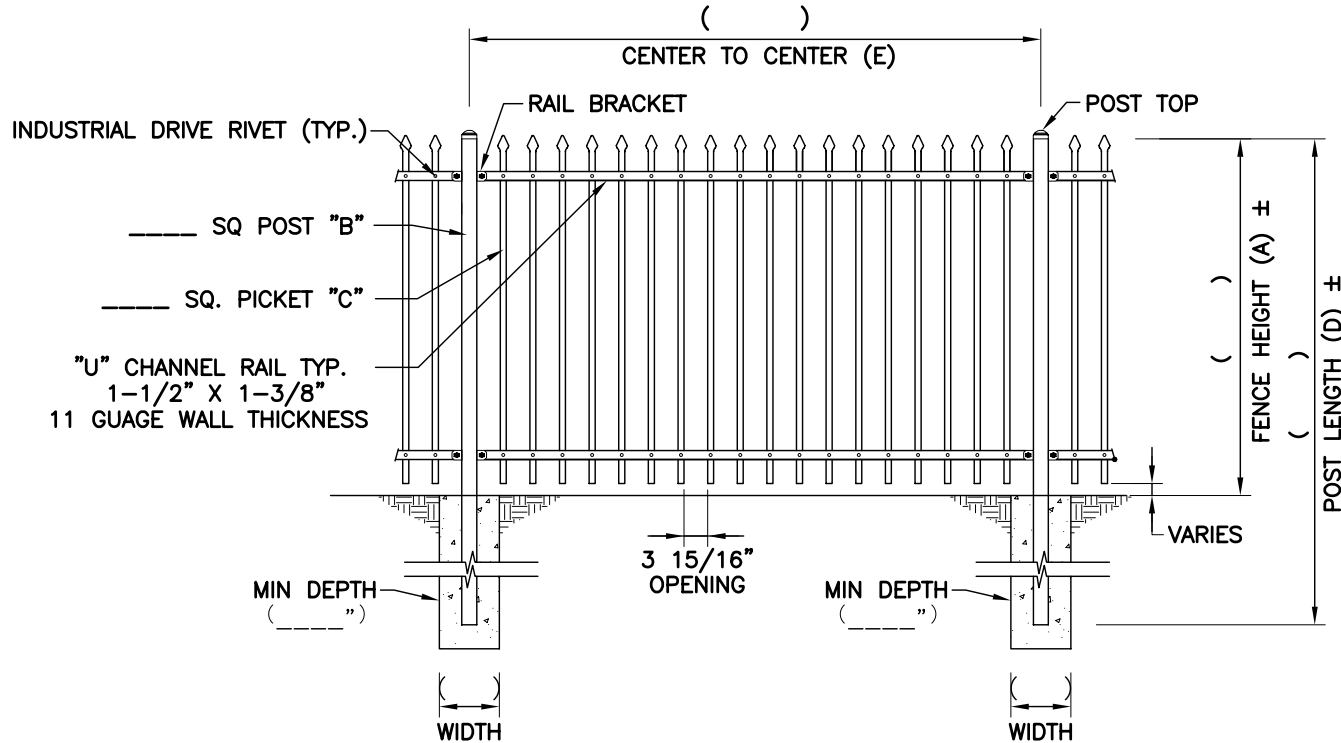

**FENCE SECTION ELEVATION**  
SCALE : NONE

**NOTES:**

1. DRAWINGS ARE NOT TO SCALE.
2. FOOTING WIDTH TO BE FOUR(4) TIMES THE POST WIDTH.
3. PICKETS SHALL BE SECURED TO RAILS WITH 1/4" ALUMINUM INDUSTRIAL DRIVE RIVETS.
4. MAXIMUM RAKE APPROXIMATELY SIX(6) INCHES.

**PICKET TOP OPTIONS**

BALL	SPEAR
FLAT CAP	PRESSED POINT

**POST TOP OPTIONS**

BALL	FLAT

**PICKET OPTION (C)**

3/4" SQ	>	18 GA
OR		16 GA
1" SQ		14 GA

- A \_\_\_\_" NOM HEIGHT
- B \_\_\_\_" POST SIZE \_\_\_\_GAUGE
- C \_\_\_\_" PICKET SIZE \_\_\_\_GAUGE
- D \_\_\_\_" POST LENGTH
- E \_\_\_\_" CENTER TO CENTER

**POST OPTION (B)**

2" SQ X 14 GA
2 1/2" SQ X 14 GA
3" SQ X 12 GA
4" SQ X 11 GA
6" SQ X 3/16" WALL
8" SQ X 1/4" WALL
10" SQ X 1/4" WALL

**NOMINAL HEIGHT (A)**

3'-0"
3'-6"
4'-0"
5'-0"
6'-0"
7'-0"
8'-0"

CAD #:	MAP
DRAWN BY:	
CKD. BY:	
DATE:	
SCALE:	NONE
SHEET NO.:	

PROJECT NO.:	
PROJECT MANAGER:	

**LONG FENCE**  
www.longfence.com  
8545 EDGEWORTH DRIVE  
CAPITOL HEIGHTS, MD, 20743  
(301) 350-2400  
6837

PROJECT:	
DRAWING TITLE:	FENCE DETAIL

SITE:	
-------	--

# Embassy

3 RAIL TUBULAR IRON SERIES, STYLE LF-EMO3

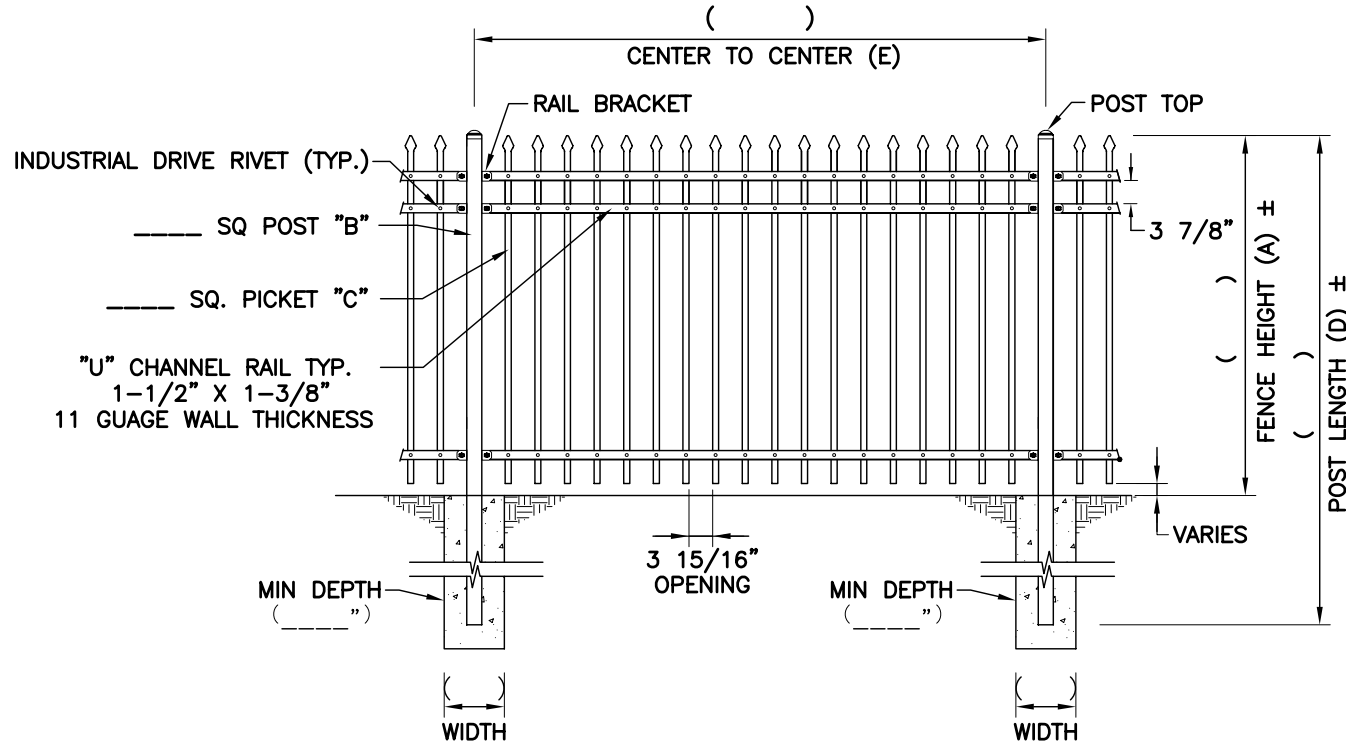





**FENCE SECTION ELEVATION**  
SCALE : NONE

**NOTES:**

1. DRAWINGS ARE NOT TO SCALE.
2. FOOTING WIDTH TO BE FOUR(4) TIMES THE POST WIDTH.
3. PICKETS SHALL BE SECURED TO RAILS WITH 1/4" ALUMINUM INDUSTRIAL DRIVE RIVETS.
4. MAXIMUM RAKE APPROXIMATELY SIX(6) INCHES.

**PICKET TOP OPTIONS**

BALL	SPEAR
	
FLAT CAP	PRESSED POINT
	

**POST TOP OPTIONS**

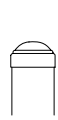
BALL	FLAT
	

**PICKET OPTION (C)**

3/4" SQ > 18 GA  
OR > 16 GA  
1" SQ > 14 GA

A \_\_\_\_" NOM HEIGHT  
B \_\_\_\_" POST SIZE \_\_\_\_ GAUGE  
C \_\_\_\_" PICKET SIZE \_\_\_\_ GAUGE  
D \_\_\_\_" POST LENGTH  
E \_\_\_\_" CENTER TO CENTER

**POST OPTION (B)**

2" SQ X 14 GA  
2 1/2" SQ X 14 GA  
3" SQ X 12 GA  
4" SQ X 11 GA  
6" SQ X 3/16" WALL  
8" SQ X 1/4" WALL  
10" SQ X 1/4" WALL

**NOMINAL HEIGHT (A)**

3'-0"  
3'-6"  
4'-0"  
5'-0"  
6'-0"  
7'-0"  
8'-0"

CAD #:	MAP
DRAWN BY:	
CKD. BY:	
DATE:	
SCALE:	NONE
SHEET NO.:	

PROJECT NO.:	
PROJECT MANAGER:	

**LONG FENCE**  
www.longfence.com  
8545 EDGEWORTH DRIVE  
CAPITOL HEIGHTS, MD, 20743  
(301) 350-2400  
6837

PROJECT	
DRAWING TITLE	FENCE DETAIL

SITE:	
-------	--

# Embassy

3 RAIL TUBULAR IRON SERIES, STYLE LF-EMO3-R1

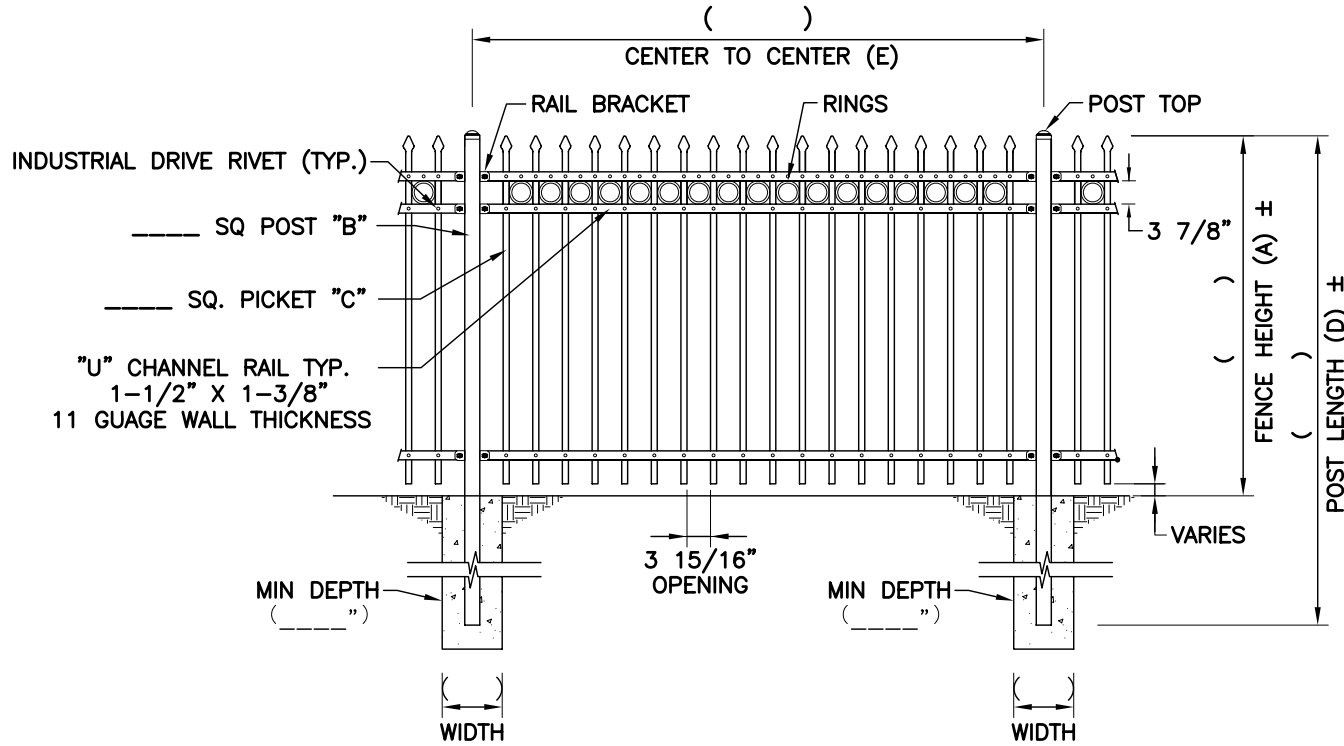

**FENCE SECTION ELEVATION**  
SCALE : NONE

**NOTES:**

1. DRAWINGS ARE NOT TO SCALE.
2. FOOTING WIDTH TO BE FOUR(4) TIMES THE POST WIDTH.
3. PICKETS SHALL BE SECURED TO RAILS WITH 1/4" ALUMINUM INDUSTRIAL DRIVE RIVETS.
4. MAXIMUM RAKE APPROXIMATELY SIX(6) INCHES.

**PICKET TOP OPTIONS**

BALL	SPEAR
FLAT CAP	PRESSED POINT

**POST TOP OPTIONS**

BALL	FLAT

**PICKET OPTION (C)**

3/4" SQ > 18 GA  
OR > 16 GA  
1" SQ > 14 GA

A \_\_\_\_" NOM HEIGHT  
B \_\_\_\_" POST SIZE \_\_\_\_GAUGE  
C \_\_\_\_" PICKET SIZE \_\_\_\_GAUGE  
D \_\_\_\_" POST LENGTH  
E \_\_\_\_" CENTER TO CENTER

**POST OPTION (B)**

2" SQ X 14 GA  
2 1/2" SQ X 14 GA  
3" SQ X 12 GA  
4" SQ X 11 GA  
6" SQ X 3/16" WALL  
8" SQ X 1/4" WALL  
10" SQ X 1/4" WALL

**NOMINAL HEIGHT (A)**

3'-0"  
3'-6"  
4'-0"  
5'-0"  
6'-0"  
7'-0"  
8'-0"

CAD #:	MAP
DRAWN BY:	
CKD. BY:	
DATE:	
SCALE:	NONE
SHEET NO.:	

PROJECT NO.:	
PROJECT MANAGER:	

**LONG FENCE**  
www.longfence.com  
8545 EDGEWORTH DRIVE  
CAPITOL HEIGHTS, MD, 20743  
(301) 350-2400  
6837

PROJECT	
DRAWING TITLE	FENCE DETAIL

SITE:	
-------	--

# Embassy

4 RAIL TUBULAR IRON SERIES, STYLE LF-EMO4

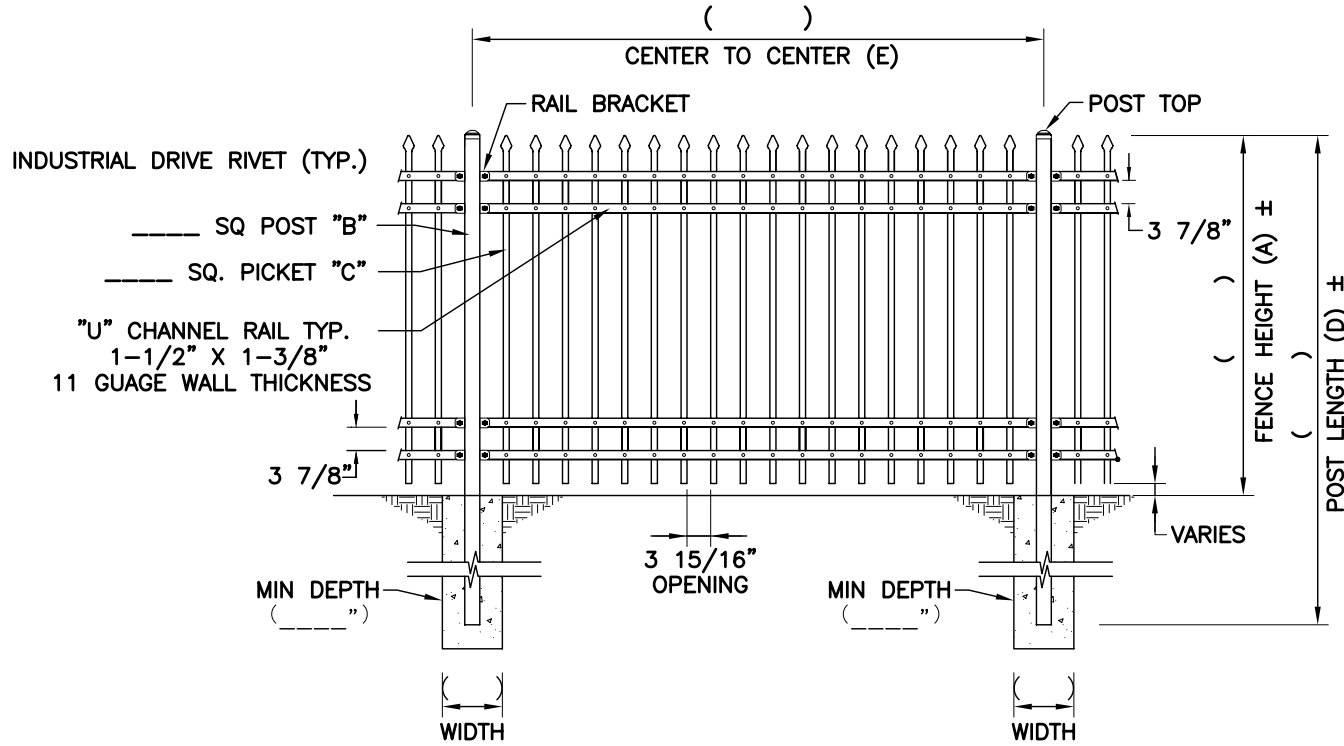





**FENCE SECTION ELEVATION**  
SCALE : NONE



**NOTES:**

1. DRAWINGS ARE NOT TO SCALE.
2. FOOTING WIDTH TO BE FOUR(4) TIMES THE POST WIDTH.
3. PICKETS SHALL BE SECURED TO RAILS WITH 1/4" ALUMINUM INDUSTRIAL DRIVE RIVETS.
4. MAXIMUM RAKE APPROXIMATELY SIX(6) INCHES.

**PICKET TOP OPTIONS**

BALL	SPEAR
	
FLAT CAP	PRESSED POINT
	

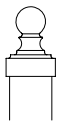
**POST TOP OPTIONS**

BALL	FLAT
	

**PICKET OPTION (C)**

3/4" SQ > 18 GA  
OR > 16 GA  
1" SQ > 14 GA

A \_\_\_\_" NOM HEIGHT  
B \_\_\_\_" POST SIZE \_\_\_\_ GAUGE  
C \_\_\_\_" PICKET SIZE \_\_\_\_ GAUGE  
D \_\_\_\_" POST LENGTH  
E \_\_\_\_" CENTER TO CENTER

**POST OPTION (B)**

2" SQ X 14 GA  
2 1/2" SQ X 14 GA  
3" SQ X 12 GA  
4" SQ X 11 GA  
6" SQ X 3/16" WALL  
8" SQ X 1/4" WALL  
10" SQ X 1/4" WALL

**NOMINAL HEIGHT (A)**

3'-0"  
3'-6"  
4'-0"  
5'-0"  
6'-0"  
7'-0"  
8'-0"

CAD #:	MAP
DRAWN BY:	
CKD. BY:	
DATE:	
SCALE:	NONE
SHEET NO.:	

PROJECT NO.:	
PROJECT MANAGER:	

**LONG FENCE**  
www.longfence.com  
8545 EDGEWORTH DRIVE  
CAPITOL HEIGHTS, MD. 20743  
(301) 350-2400  
6837

PROJECT	
DRAWING TITLE	FENCE DETAIL

SITE:	
-------	--

# Embassy

4 RAIL TUBULAR IRON SERIES, STYLE LF-EMO4-R1

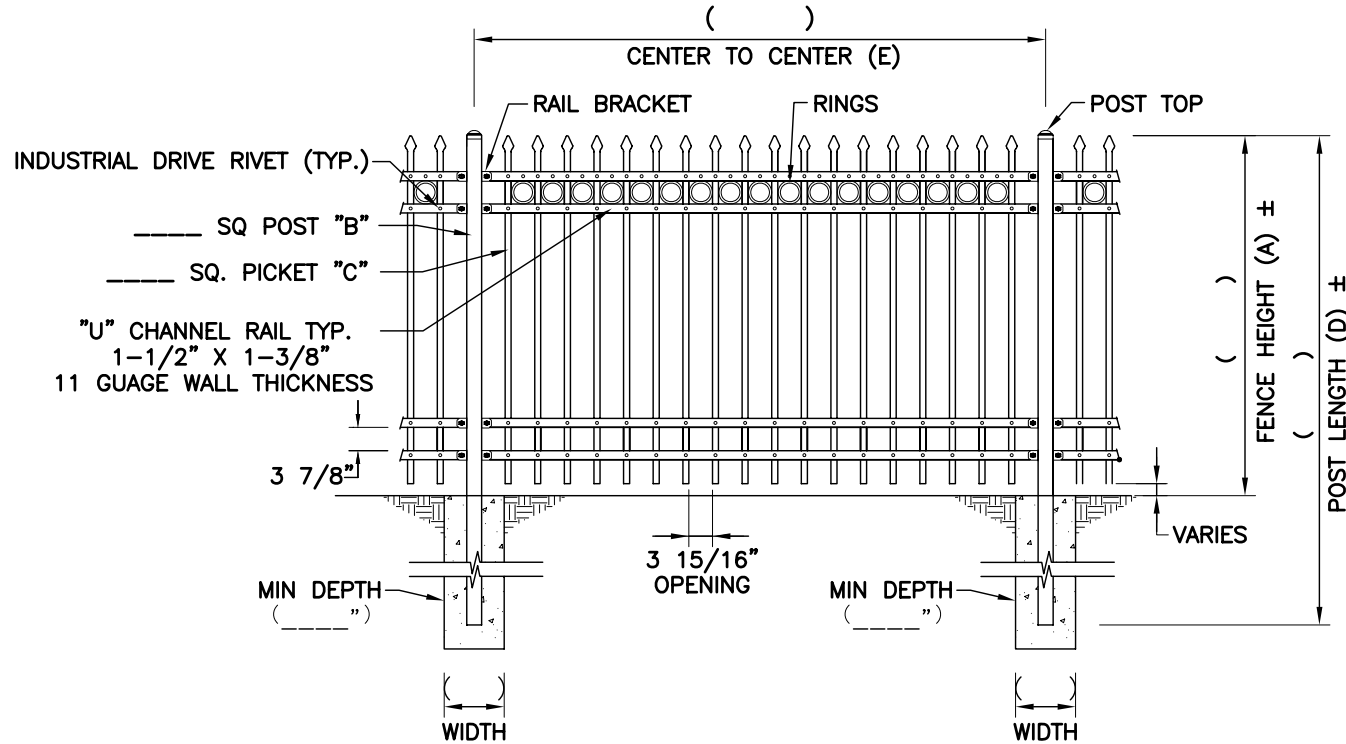

**FENCE SECTION ELEVATION**  
SCALE : NONE

**NOTES:**

1. DRAWINGS ARE NOT TO SCALE.
2. FOOTING WIDTH TO BE FOUR(4) TIMES THE POST WIDTH.
3. PICKETS SHALL BE SECURED TO RAILS WITH 1/4" ALUMINUM INDUSTRIAL DRIVE RIVETS.
4. MAXIMUM RAKE APPROXIMATELY SIX(6) INCHES.

**PICKET TOP OPTIONS**

BALL	SPEAR
FLAT CAP	PRESSED POINT

**POST TOP OPTIONS**

BALL	FLAT

**PICKET OPTION (C)**

3/4" SQ > 18 GA  
OR > 16 GA  
1" SQ > 14 GA

A \_\_\_\_" NOM HEIGHT  
B \_\_\_\_" POST SIZE \_\_\_\_GAUGE  
C \_\_\_\_" PICKET SIZE \_\_\_\_GAUGE  
D \_\_\_\_" POST LENGTH  
E \_\_\_\_" CENTER TO CENTER

**POST OPTION (B)**

2" SQ X 14 GA  
2 1/2" SQ X 14 GA  
3" SQ X 12 GA  
4" SQ X 11 GA  
6" SQ X 3/16" WALL  
8" SQ X 1/4" WALL  
10" SQ X 1/4" WALL

**NOMINAL HEIGHT (A)**

3'-0"  
3'-6"  
4'-0"  
5'-0"  
6'-0"  
7'-0"  
8'-0"

CAD #:	MAP
DRAWN BY:	
CKD. BY:	
DATE:	
SCALE:	NONE
SHEET NO.:	

PROJECT NO.:	
PROJECT MANAGER:	

**LONG FENCE**  
www.longfence.com  
8545 EDGEWORTH DRIVE  
CAPITOL HEIGHTS, MD. 20743  
(301) 350-2400  
6837

PROJECT:	
DRAWING TITLE:	FENCE DETAIL

SITE:	
-------	--

# Embassy

4 RAIL TUBULAR IRON SERIES, STYLE LF-EMO4-R2

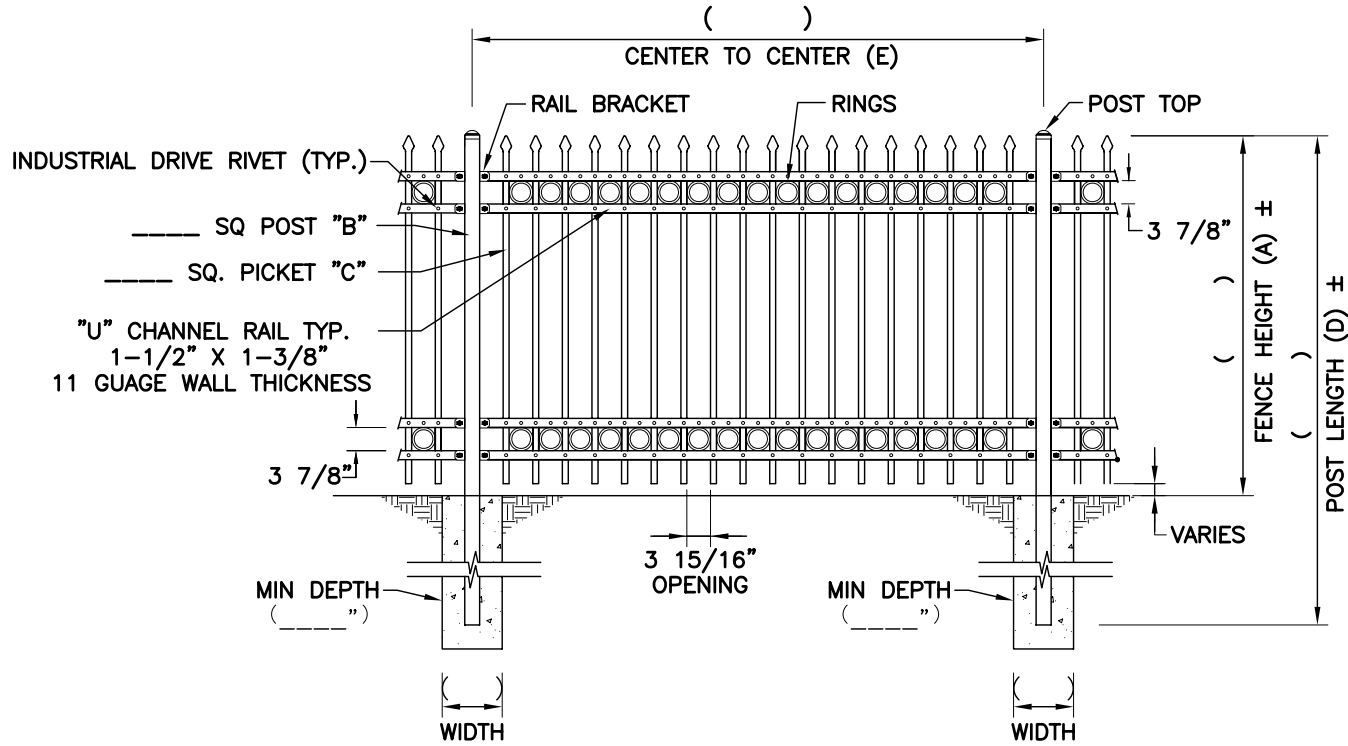





**FENCE SECTION ELEVATION**  
SCALE : NONE



**NOTES:**

1. DRAWING SCALE IS DRAWING SCALE.
2. FOOTING WIDTH TO BE FOUR(4) TIMES THE POST WIDTH.
3. PICKETS SHALL BE SECURED TO RAILS WITH 1/4" ALUMINUM INDUSTRIAL DRIVE RIVETS.
4. MAXIMUM RAKE APPROXIMATELY SIX(6) INCHES.

**PICKET TOP OPTIONS**

BALL	SPEAR
	
FLAT CAP	PRESSED POINT
	

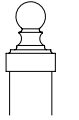
**POST TOP OPTIONS**

BALL	FLAT
	

**PICKET OPTION (C)**

3/4" SQ > 18 GA  
OR > 16 GA  
1" SQ > 14 GA

A \_\_\_\_" NOM HEIGHT  
B \_\_\_\_" POST SIZE \_\_\_\_ GAUGE  
C \_\_\_\_" PICKET SIZE \_\_\_\_ GAUGE  
D \_\_\_\_" POST LENGTH  
E \_\_\_\_" CENTER TO CENTER

**POST OPTION (B)**

2" SQ X 14 GA  
2 1/2" SQ X 14 GA  
3" SQ X 12 GA  
4" SQ X 11 GA  
6" SQ X 3/16" WALL  
8" SQ X 1/4" WALL  
10" SQ X 1/4" WALL

**NOMINAL HEIGHT (A)**

3'-0"  
3'-6"  
4'-0"  
5'-0"  
6'-0"  
7'-0"  
8'-0"

CAD #:	MAP
DRAWN BY:	
CKD. BY:	
DATE:	
SCALE:	NONE
SHEET NO.:	

PROJECT NO.:	
PROJECT MANAGER:	

**LONG FENCE**  
www.longfence.com  
8545 EDGEWORTH DRIVE  
CAPITOL HEIGHTS, MD. 20743  
(301) 350-2400  
6837

PROJECT	
DRAWING TITLE	FENCE DETAIL

SITE:	
-------	--