

# Diplomat

2 RAIL TUBULAR IRON SERIES, STYLE LF-D02

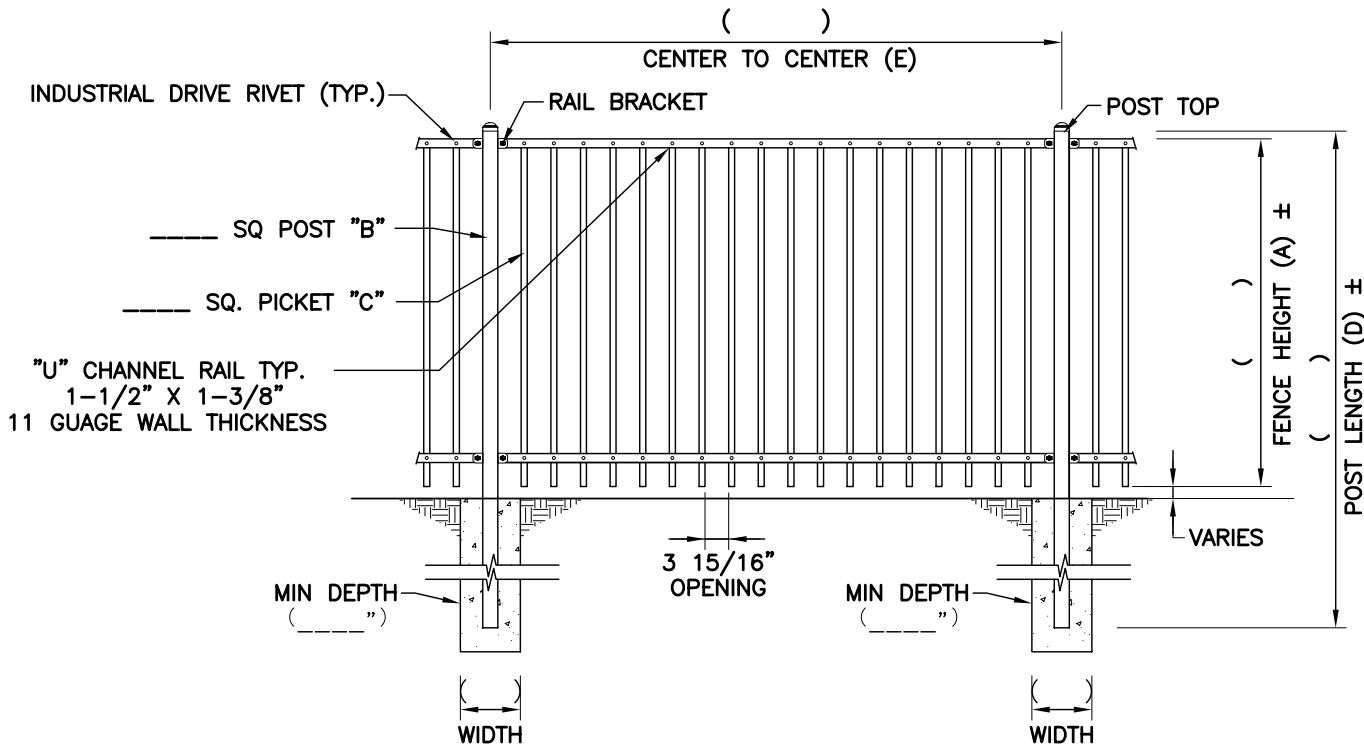

**FENCE SECTION ELEVATION**  
SCALE : NONE

**NOTES:**

1. DRAWINGS ARE NOT TO SCALE.
2. FOOTING WIDTH TO BE FOUR(4) TIMES THE POST WIDTH.
3. PICKETS SHALL BE SECURED TO RAILS WITH 1/4" ALUMINUM INDUSTRIAL DRIVE RIVETS.
4. MAXIMUM RAKE APPROXIMATELY SIX(6) INCHES.

| POST TOP OPTIONS |      |
|------------------|------|
| BALL             | FLAT |
|                  |      |

| PICKET OPTION (C) | A ____" NOM HEIGHT            |
|-------------------|-------------------------------|
| 3/4" SQ > 18 GA   | B ____" POST SIZE ____GAUGE   |
| OR > 16 GA        | C ____" PICKET SIZE ____GAUGE |
| 1" SQ > 14 GA     | D ____" POST LENGTH           |
|                   | E ____" CENTER TO CENTER      |

| POST OPTION (B)    | NOMINAL HEIGHT (A) |
|--------------------|--------------------|
| 2" SQ X 14 GA      | 3'-0"              |
| 2 1/2" SQ X 14 GA  | 3'-6"              |
| 3" SQ X 12 GA      | 4'-0"              |
| 4" SQ X 11 GA      | 5'-0"              |
| 6" SQ X 3/16" WALL | 6'-0"              |
| 8" SQ X 1/4" WALL  | 7'-0"              |
| 10" SQ X 1/4" WALL | 8'-0"              |

|            |      |
|------------|------|
| CAD #:     | MAP  |
| DRAWN BY:  |      |
| CKD. BY:   |      |
| DATE:      |      |
| SCALE:     | NONE |
| SHEET NO.: |      |

|              |                 |
|--------------|-----------------|
| PROJECT NO.: | PROJECT MANAGER |
|--------------|-----------------|

**LONG FENCE**  
[www.longfence.com](http://www.longfence.com)  
 8545 EDGEWORTH DRIVE  
 CAPITOL HEIGHTS, MD, 20743  
 (301) 350-2400  
 8687

|         |               |
|---------|---------------|
| PROJECT | DRAWING TITLE |
|         | FENCE DETAIL  |

|       |
|-------|
| SITE: |
|-------|



# Diplomat

3 RAIL W/ RINGS TUBULAR IRON SERIES, STYLE LF-DO3-R1

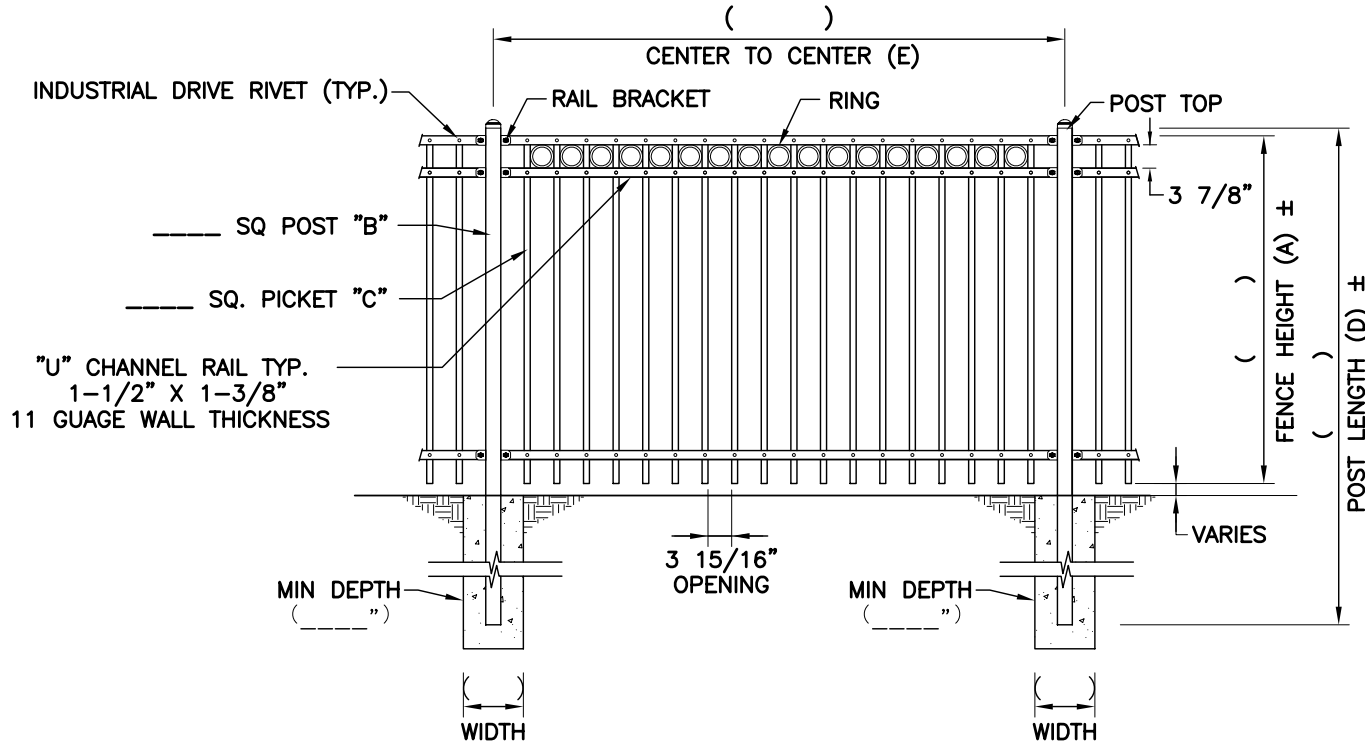

**FENCE SECTION ELEVATION**  
SCALE : NONE

**NOTES:**

1. DRAWINGS ARE NOT TO SCALE.
2. FOOTING WIDTH TO BE FOUR(4) TIMES THE POST WIDTH.
3. PICKETS SHALL BE SECURED TO RAILS WITH 1/4" ALUMINUM INDUSTRIAL DRIVE RIVETS.
4. MAXIMUM RAKE APPROXIMATELY SIX(6) INCHES.

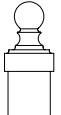
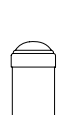
| POST TOP OPTIONS                                                                    |                                                                                     |
|-------------------------------------------------------------------------------------|-------------------------------------------------------------------------------------|
| BALL                                                                                | FLAT                                                                                |
|  |  |

| PICKET OPTION (C) |       |
|-------------------|-------|
| 3/4" SQ           | 18 GA |
| OR                | 16 GA |
| 1" SQ             | 14 GA |

|   |                            |
|---|----------------------------|
| A | ___" NOM HEIGHT            |
| B | ___" POST SIZE ___ GAUGE   |
| C | ___" PICKET SIZE ___ GAUGE |
| D | ___" POST LENGTH           |
| E | ___" CENTER TO CENTER      |

| POST OPTION (B)    | NOMINAL HEIGHT (A) |
|--------------------|--------------------|
| 2" SQ X 14 GA      | 3'-0"              |
| 2 1/2" SQ X 14 GA  | 3'-6"              |
| 3" SQ X 12 GA      | 4'-0"              |
| 4" SQ X 11 GA      | 5'-0"              |
| 6" SQ X 3/16" WALL | 6'-0"              |
| 8" SQ X 1/4" WALL  | 7'-0"              |
| 10" SQ X 1/4" WALL | 8'-0"              |

|            |      |
|------------|------|
| CAD #:     | MAP  |
| DRAWN BY:  |      |
| CKD. BY:   |      |
| DATE:      |      |
| SCALE:     | NONE |
| SHEET NO.: |      |

|                  |  |
|------------------|--|
| PROJECT NO.:     |  |
| PROJECT MANAGER: |  |

**LONG FENCE**  
www.longfence.com  
8545 EDGEWORTH DRIVE  
CAPITOL HEIGHTS, MD, 20743  
(301) 350-2400  
6837

|               |              |
|---------------|--------------|
| PROJECT       |              |
| DRAWING TITLE | FENCE DETAIL |

|       |  |
|-------|--|
| SITE: |  |
|-------|--|

# Diplomat

4 RAIL TUBULAR IRON SERIES, STYLE LF-D04

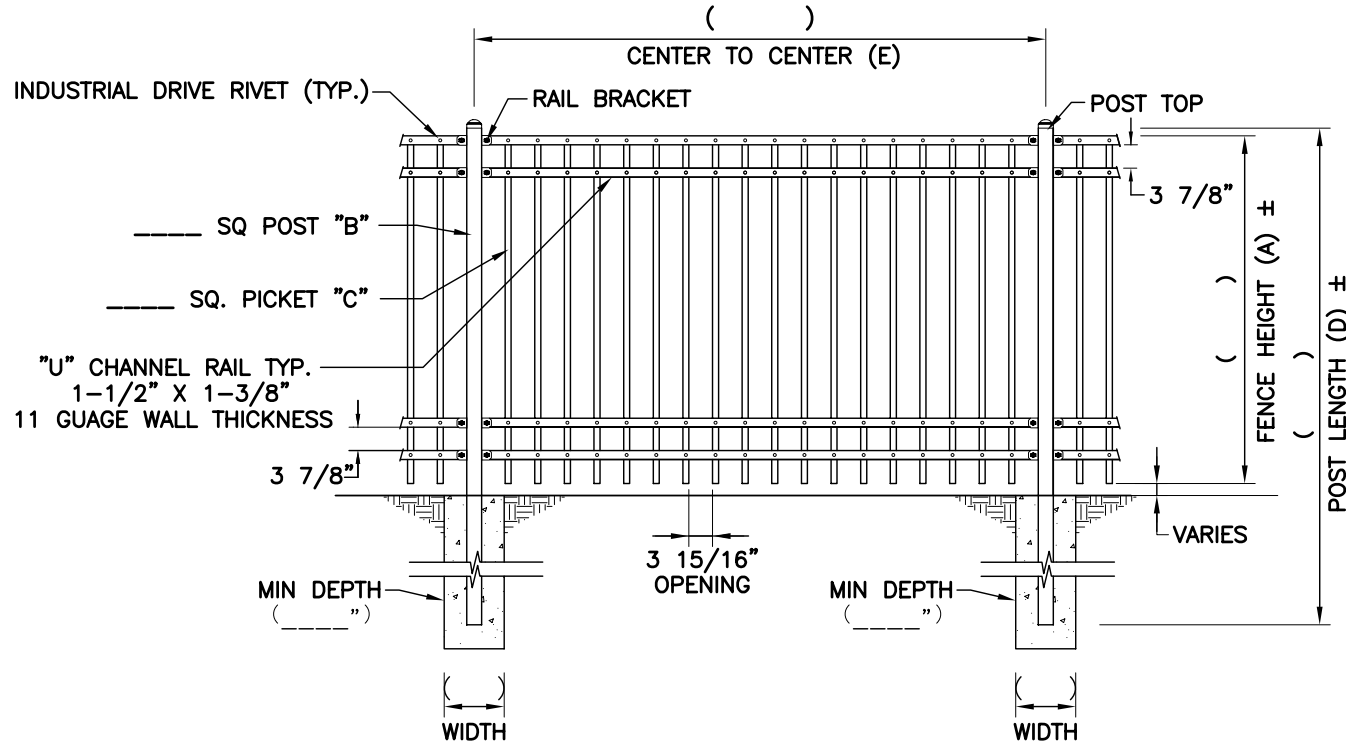

**FENCE SECTION ELEVATION**  
SCALE : NONE

**NOTES:**

1. DRAWINGS ARE NOT TO SCALE.
2. FOOTING WIDTH TO BE FOUR(4) TIMES THE POST WIDTH.
3. PICKETS SHALL BE SECURED TO RAILS WITH 1/4" ALUMINUM INDUSTRIAL DRIVE RIVETS.
4. MAXIMUM RAKE APPROXIMATELY SIX(6) INCHES.

**POST TOP OPTIONS**

BALL      FLAT

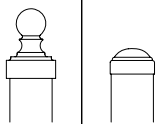

**PICKET OPTION (C)**

3/4" SQ > 18 GA  
OR > 16 GA  
1" SQ > 14 GA

A \_\_\_\_" NOM HEIGHT  
B \_\_\_\_" POST SIZE \_\_\_\_GAUGE  
C \_\_\_\_" PICKET SIZE \_\_\_\_GAUGE  
D \_\_\_\_" POST LENGTH  
E \_\_\_\_" CENTER TO CENTER

**POST OPTION (B)**

2" SQ X 14 GA  
2 1/2" SQ X 14 GA  
3" SQ X 12 GA  
4" SQ X 11 GA  
6" SQ X 3/16" WALL  
8" SQ X 1/4" WALL  
10" SQ X 1/4" WALL

**NOMINAL HEIGHT (A)**

3'-0"  
3'-6"  
4'-0"  
5'-0"  
6'-0"  
7'-0"  
8'-0"

|            |      |
|------------|------|
| CAD #:     | MAP  |
| DRAWN BY:  |      |
| CKD. BY:   |      |
| DATE:      |      |
| SCALE:     | NONE |
| SHEET NO.: |      |

|                  |  |
|------------------|--|
| PROJECT NO.:     |  |
| PROJECT MANAGER: |  |

**LONG FENCE**  
www.longfence.com  
8545 EDGEWORTH DRIVE  
CAPITOL HEIGHTS, MD, 20743  
(301) 350-2400  
6837

|                |              |
|----------------|--------------|
| PROJECT:       |              |
| DRAWING TITLE: | FENCE DETAIL |

|       |  |
|-------|--|
| SITE: |  |
|-------|--|

# Diplomat

4 RAIL TUBULAR IRON SERIES, STYLE LF-D04-R1

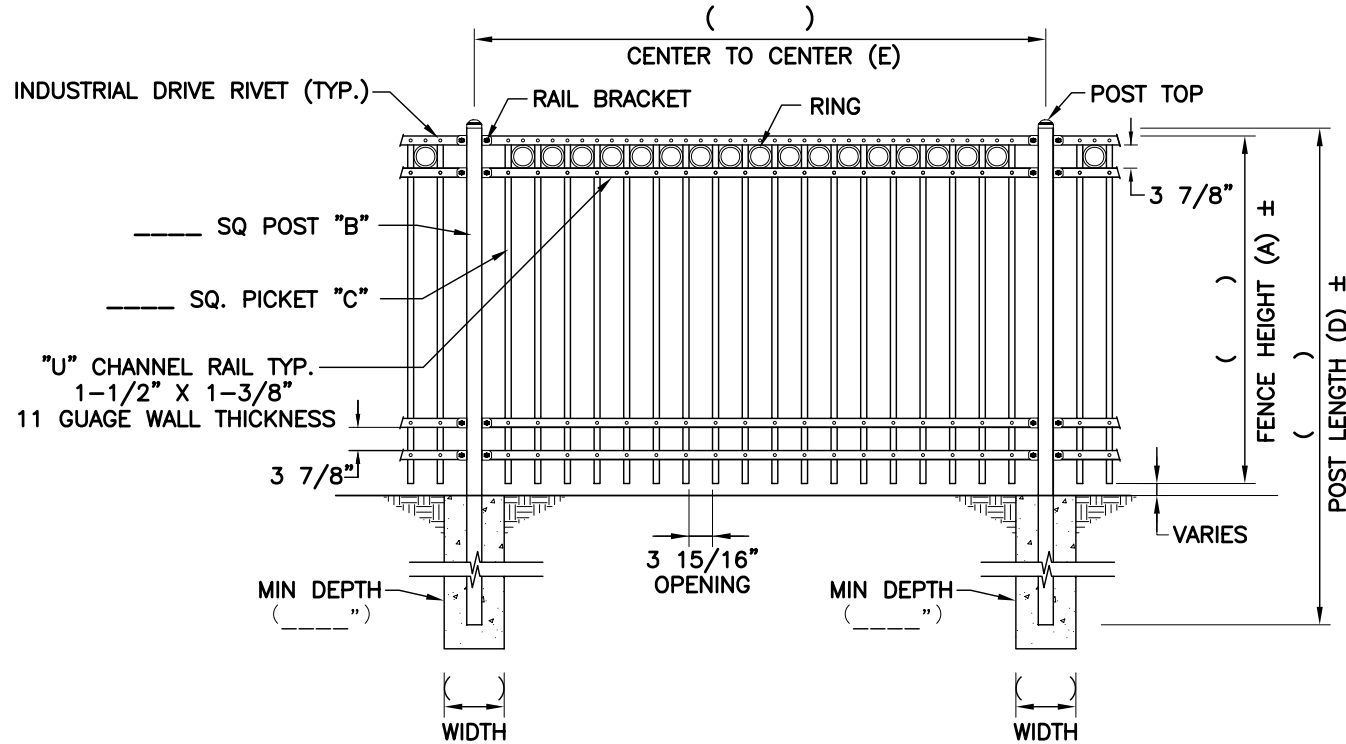

**FENCE SECTION ELEVATION**  
SCALE : NONE

**NOTES:**

1. DRAWINGS ARE NOT TO SCALE.
2. FOOTING WIDTH TO BE FOUR(4) TIMES THE POST WIDTH.
3. PICKETS SHALL BE SECURED TO RAILS WITH 1/4" ALUMINUM INDUSTRIAL DRIVE RIVETS.
4. MAXIMUM RAKE APPROXIMATELY SIX(6) INCHES.

**POST TOP OPTIONS**

BALL      FLAT

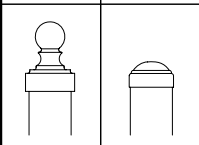

**PICKET OPTION (C)**

3/4" SQ > 18 GA  
OR > 16 GA  
1" SQ > 14 GA

A \_\_\_\_" NOM HEIGHT  
B \_\_\_\_" POST SIZE \_\_\_\_ GAUGE  
C \_\_\_\_" PICKET SIZE \_\_\_\_ GAUGE  
D \_\_\_\_" POST LENGTH  
E \_\_\_\_" CENTER TO CENTER

**POST OPTION (B)**

2" SQ X 14 GA  
2 1/2" SQ X 14 GA  
3" SQ X 12 GA  
4" SQ X 11 GA  
6" SQ X 3/16" WALL  
8" SQ X 1/4" WALL  
10" SQ X 1/4" WALL

**NOMINAL HEIGHT (A)**

3'-0"  
3'-6"  
4'-0"  
5'-0"  
6'-0"  
7'-0"  
8'-0"

|            |      |
|------------|------|
| CAD #:     | MAP  |
| DRAWN BY:  |      |
| CKD. BY:   |      |
| DATE:      |      |
| SCALE:     | NONE |
| SHEET NO.: |      |

|                  |  |
|------------------|--|
| PROJECT NO.:     |  |
| PROJECT MANAGER: |  |

**LONG FENCE**  
www.longfence.com  
8545 EDGEWORTH DRIVE  
CAPITOL HEIGHTS, MD. 20743  
(301) 350-2400  
6837

|                |              |
|----------------|--------------|
| PROJECT:       |              |
| DRAWING TITLE: | FENCE DETAIL |

|       |  |
|-------|--|
| SITE: |  |
|-------|--|

# Diplomat

4 RAIL TUBULAR IRON SERIES, STYLE LF-DO4-R2

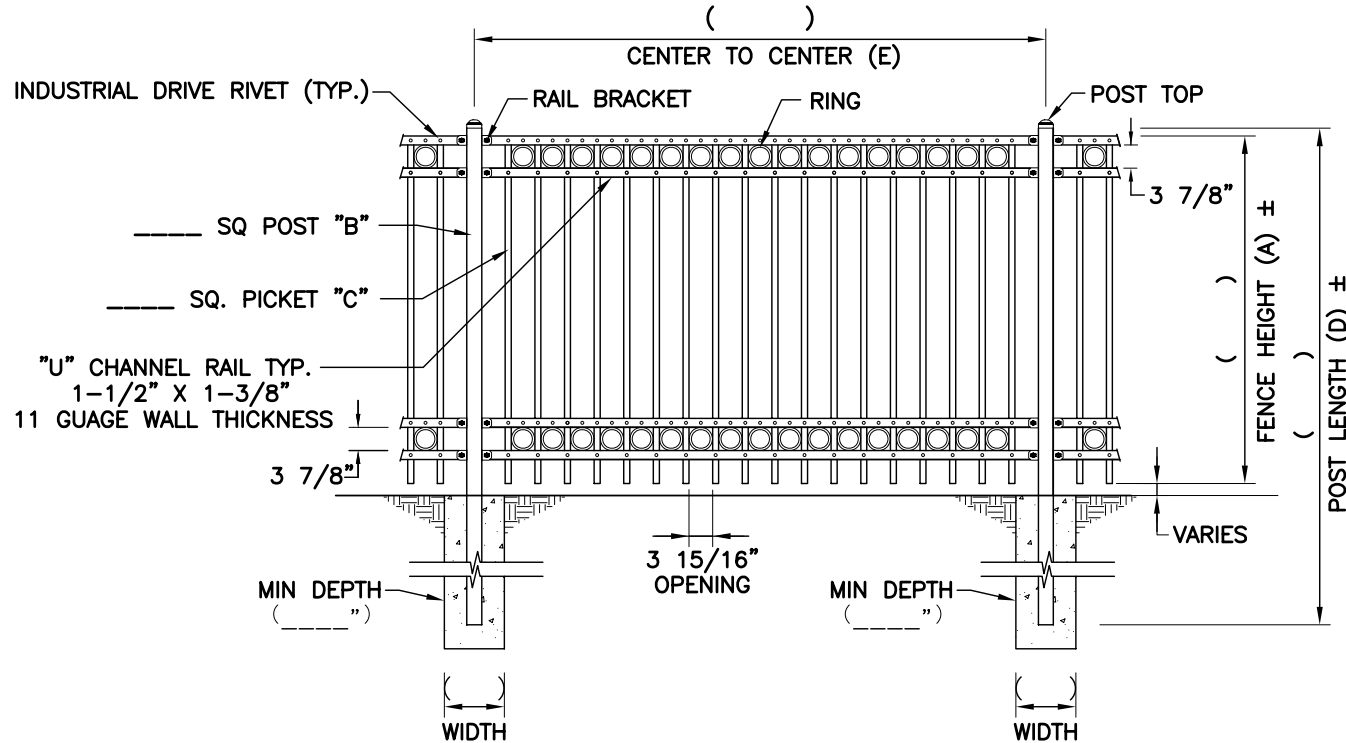

**FENCE SECTION ELEVATION**  
SCALE : NONE

**NOTES:**

1. DRAWINGS ARE NOT TO SCALE.
2. FOOTING WIDTH TO BE FOUR(4) TIMES THE POST WIDTH.
3. PICKETS SHALL BE SECURED TO RAILS WITH 1/4" ALUMINUM INDUSTRIAL DRIVE RIVETS.
4. MAXIMUM RAKE APPROXIMATELY SIX(6) INCHES.

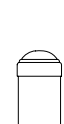
| POST TOP OPTIONS                                                                    |                                                                                     |
|-------------------------------------------------------------------------------------|-------------------------------------------------------------------------------------|
| BALL                                                                                | FLAT                                                                                |
|  |  |

| PICKET OPTION (C) |       |
|-------------------|-------|
| 3/4" SQ           | 18 GA |
| OR                | 16 GA |
| 1" SQ             | 14 GA |

|   |                           |
|---|---------------------------|
| A | ___" NOM HEIGHT           |
| B | ___" POST SIZE ___GAUGE   |
| C | ___" PICKET SIZE ___GAUGE |
| D | ___" POST LENGTH          |
| E | ___" CENTER TO CENTER     |

| POST OPTION (B)    | NOMINAL HEIGHT (A) |
|--------------------|--------------------|
| 2" SQ X 14 GA      | 3'-0"              |
| 2 1/2" SQ X 14 GA  | 3'-6"              |
| 3" SQ X 12 GA      | 4'-0"              |
| 4" SQ X 11 GA      | 5'-0"              |
| 6" SQ X 3/16" WALL | 6'-0"              |
| 8" SQ X 1/4" WALL  | 7'-0"              |
| 10" SQ X 1/4" WALL | 8'-0"              |

|            |      |
|------------|------|
| CAD #:     | MAP  |
| DRAWN BY:  |      |
| CHKD. BY:  |      |
| DATE:      |      |
| SCALE:     | NONE |
| SHEET NO.: |      |

|                  |  |
|------------------|--|
| PROJECT NO.:     |  |
| PROJECT MANAGER: |  |

**LONG FENCE**  
www.longfence.com  
8545 EDGEWORTH DRIVE  
CAPITOL HEIGHTS, MD. 20743  
(301) 350-2400  
6837

|                |              |
|----------------|--------------|
| PROJECT:       |              |
| DRAWING TITLE: | FENCE DETAIL |

|       |  |
|-------|--|
| SITE: |  |
|-------|--|